

Raman, hyper-Raman, hyper-Rayleigh, two-photon luminescence and morphology-dependent resonance modes in a single optical tweezers system

A. Fontes,¹ K. Ajito,² A. A. R. Neves,¹ W. L. Moreira,¹ A. A. de Thomaz,¹ L. C. Barbosa,¹
A. M. de Paula,³ and C. L. Cesar¹

¹*Instituto de Física “Gleb Wataghin,” UNICAMP, 13083-970, Campinas-SP, Brazil*

²*Bio-Science Research Group, Basic Research Laboratories, Nippon Telegraph and Telephone (NTT) Corporation, Kanagawa, Japan*

³*School of Physics and Astronomy, University of Southampton, Southampton, United Kingdom*

(Received 24 November 2004; published 22 July 2005)

We present a setup of optical tweezers combined with linear and nonlinear microspectroscopies that enhances the capabilities of capture and analysis of both techniques. We can use either a continuous-wave (cw) Ti:sapphire laser for Raman measurements or a pulsed femtosecond Ti:sapphire laser that permitted the observation of nonlinear results such as hyper-Raman, hyper-Rayleigh, and two-photon luminescence. Only the high peak intensity of the femtosecond laser allows the observation of all these nonlinear spectroscopies. The sensitivity of our system also permitted the observation of morphology-dependent resonance (MDR) modes of a single stained trapped microsphere of 6 μm . The possibility of performing spectroscopy in a living microorganism optically trapped in any desired neighborhood would mean that one can dynamically observe the chemical reactions and/or mechanical properties changing in real time.

DOI: [10.1103/PhysRevE.72.012903](https://doi.org/10.1103/PhysRevE.72.012903)

PACS number(s): 87.64.-t, 87.80.-y

Single-beam optical tweezers have been used as a tool to manipulate biological material at cellular level, as well as to measure mechanical properties such as femtonewton force and stiffnesses or elasticity of membranes and single DNA macromolecules [1–6]. Also the recent review by David Grier [7] shows their application in many fields of research ranging from physics to life sciences. We used optical tweezers to study diseases related to the mechanical properties of individual red blood cells [8] and we showed the importance of using spectroscopic techniques while manipulating particles and living cells. The ability of performing spectroscopy in a living microorganism optically trapped in any desired neighbourhood means that one can dynamically observe the chemical reactions and/or mechanical properties changing in real time.

In this paper we present a combined setup using optical tweezers for micro spectroscopy measurements, including Raman, hyper-Raman, hyper-Rayleigh and two-photon luminescence. Our setup consists of femtosecond and/or cw Ti:sapphire lasers for trapping and spectroscopic measurements, another Nd:YAG laser only for trapping and a homemade confocal spectrometer using a monochromator equipped with a liquid nitrogen cooled CCD. The use of a femtosecond laser, with or without another cw laser for trapping, opens up a great number of different applications and spectroscopies as compared with previous works [9–12]. Two photon optical processes depend on the square of the laser intensity, thus there is virtually no luminescence signal out of the focal spot (a spot already smaller than the focal spot for one photon only). Therefore the signal collection optics are not so important as in the conventional confocal techniques what leads to confocal multiphoton microscopy [13]. Some of the advantages of using an infrared laser for two-photon luminescence of living cells are the resolution and the absence of damage caused by the heat. The drawback of luminescence for living cells is that the nonradiative de-

caying usually requires cell staining that can kill them. However not only luminescence can be excited by the femtosecond laser, but also hyper-Rayleigh and hyper-Raman. These spectroscopic techniques and the optical tweezers mounted as a one system can provide a thorough analysis from visible to infrared regions of all kinds of living cells (flagellate or immovable) and other single trapped particles such as single trapped polystyrene microspheres and red blood cells.

We also observed morphology-dependent resonance modes (or Mie resonances) on the two-photon luminescence of a single 6 μm polystyrene microsphere captured by the optical tweezers which demonstrates the sensitivity of our system. Agate *et al.* [14] have also first shown two-photon fluorescence on a trapped microsphere. However, to the best of our knowledge, this is the first time that the MDR modes are excited, observed and generated by two-photon absorption in a polystyrene microsphere captured by an optical tweezers. The microcavity spectral response, the long optical paths of the trapped light and their very high Q values can be used for several applications, such as quantum optics, optical amplifiers and lasers or dynamic filters [15–17]. The microcavity enhancement of the linear and nonlinear spectral signal of substances bonded to cavity surface allows the construction of biosensors [18,19]. The water droplets cavity enhancement can also be used to perform environmental atmospheric studies such as measurement of $p\text{H}$ or chemicals in the troposphere and stratosphere [20,21]. The quantum optics studies require very high Q values only obtained with large spheres ($>50 \mu\text{m}$) in air or vacuum [15]. These are not possible with few micrometers spheres suspended in liquids with close refractive indexes, but Q value of order of 10^3 are good enough to enhance the linear and nonlinear spectral signals. On the other hand, the microcavity can be placed inside biological solutions or, for small beads, even inside big living cells. Our setup can address the two important issues of how to hold a single microcavity and how to couple

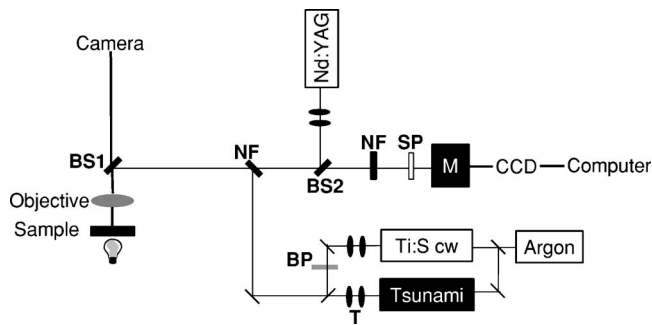

FIG. 1. Complete system for microspectroscopy (Raman, hyper-Raman, hyper-Rayleigh and two-photon luminescence) plus optical tweezers. BS1 is a metallic beam-splitter, BS2 is a dichroic mirror of Nd:YAG, BP is the band pass filter for Raman, SP is the short pass filter for hyper-Rayleigh/hyper-Raman, T is the telescope, and M is the monochromator.

the light in, for which tapered optical fibers or prisms have been used [16,22,23]. The spherical geometry of the wave equation problem would be spoiled if the cavity must touch a supporting surface. The use of two lasers, one as the optical tweezers that holds a single cavity suspended and another, cw or pulsed, laser to couple light into the microcavity, provides enough freedom to perform all kinds of linear and non-linear microcavity enhanced spectroscopies.

The lasers used in our micro-spectroscopy optical tweezers setup are a cw Ti:sapphire laser (700–900 nm, model 3900S, Spectra Physics), a femtosecond Ti:sapphire laser (700–900 nm, Tsunami, Spectra Physics), and a Nd:YAG laser (1064 nm, model 3800S, Spectra Physics). The cw Ti:sapphire laser was used for the optical tweezers and the Raman excitation. The femtosecond laser was used to perform the two-photon luminescence measurements. Both lasers were operating at 785 nm. The Nd:YAG laser was used just for the optical tweezers. The laser beams were focused through a $100\times$ oil immersion (SPlan) or $60\times$ (Apochromatic) objective in an Olympus microscope (BH2, Olympus Optical CO., Ltd.). The images of the particles were recorded using a camera (TK1085-U, JVC-Victor Company of Japan, Ltd.). We used the translation motorized stage Prior Scientific, model ProScan) to control the x , y , and z microscope movements by a computer or joystick. The signals were collected in a back-scattering geometry using the microscope objective and sent to a 30 cm monochromator (Acton Research, model 300i) equipped with a back-illuminated refrigerated CCD detector (Princeton Instruments-LNCCD 1340/100 EB/1), as shown in Fig. 1. The metallic beam-splitter BS1 reflectivity is about the same for all lasers of the system. A super notch filter (NF-Kaiser Optics Super Notch Plus with 350 cm^{-1} rejection bandwidth) was used as a mirror to reflect both the femtosecond and the cw Ti:sapphire laser beams to the microscope and to act as a notch filter for the backscattered light. The Nd:YAG laser beam is 100% transmitted to the microscope and rejected to the CCD by using a dichroic mirror (BS2). A set of telescopes are part of the system to capture and to generated the signal on the microscope focal plane. The hyper-Raman, hyper-Rayleigh and the two-photon fluorescence system are confocal by themselves,

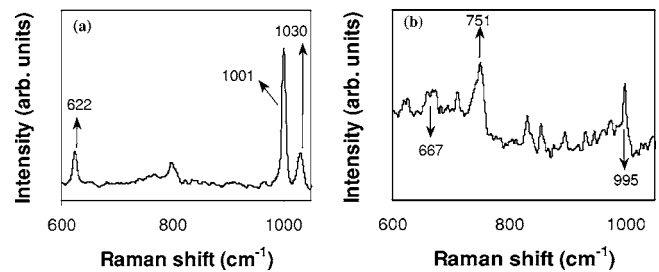

FIG. 2. Raman spectra of a single polystyrene microsphere of $6\text{ }\mu\text{m}$ (a) and a single red blood cell (b) captured by optical tweezers.

since all of them need the absorption of two photons that occurs only at the laser focus. The Raman system, which is not a self-confocal system, was done to be confocal by (focusing) the backscattering signal, coming from the microscope focal plane, at the monochromator entrance slit. For the Raman spectroscopy we had to use a band pass filter (BP-Omega Filters) to decrease the spectral width of the laser beam and another notch filter (NF) in front of the monochromator. For the hyper-Raman, hyper-Rayleigh and two-photon luminescence experiments there was no need to use neither the band pass nor the additional notch filter. We used only a short pass colour filter (SP-Newport) that transmits the visible and cuts the infrared region.

We performed the spectroscopies for samples captured and not captured by the optical tweezers. Before we obtained the new results of hyper-Raman, hyper-Rayleigh and the MDR modes, we first tested the system measuring known samples. We acquired a set of the Raman spectra for a range of samples such as: silicon, TiO_2 (anatase), ZnSe, single trapped polystyrene microspheres (Polysciences) and a single captured living red blood cell. The microspheres, diluted in water, and the red blood cell, diluted in 1:100 μL in saline solution, were placed in a Neubauer chamber. The hyper-Raman spectra were obtained for SrTiO_3 . The measurements of two-photon luminescence was done for ZnSe, fluorophores and a set of stained microspheres of 2.5 and $6\text{ }\mu\text{m}$ (molecular probes). We observed the MDR modes for a microsphere of $6\text{ }\mu\text{m}$ which emits in the blue region.

The test of the calibration and performance of the setup was done acquiring the Raman spectrum of a crystalline silicon sample, showing a sharp TO mode at 521 cm^{-1} , with a 1 s acquisition time at the same experimental conditions as the other spectra acquisition. Figure 2 shows the Raman spectra for a single trapped polystyrene microsphere, Fig. 2(a), and a single red blood cell, Fig. 2(b). The spectra were obtained for a cw laser power of 20 mW and an acquisition time of 2 s (microsphere) and 120 s (red blood cell). The fresh blood sample was obtained from donors at the Hematology and Hemotherapy Center of Campinas. The microsphere and the red blood cell solutions were analyzed in a $100\text{ }\mu\text{m}$ depth Neubauer slip at the position of approximately $20\text{ }\mu\text{m}$ from the bottom plate. The red blood cell peaks at 667, 751, and 995 cm^{-1} correspond, respectively, to ν_7 haem, ν_{14} haem, and $\nu(C_bC_1)$ bands [10]. The microsphere peaks, around 1001 and 1030 cm^{-1} , are attributed to phenyl groups of polystyrene [24].

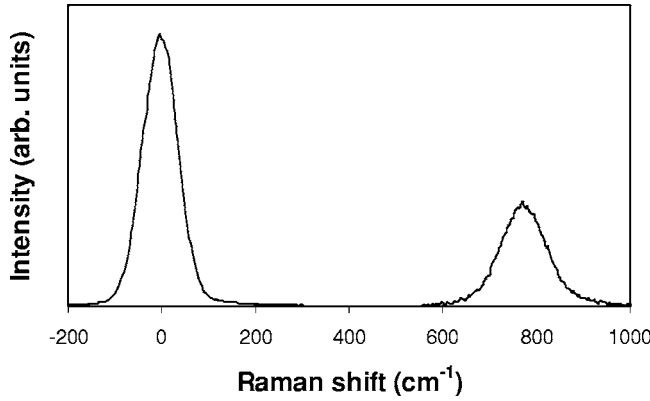

FIG. 3. Hyper Rayleigh and hyper Raman ($\times 10$) of SrTiO_3 measured in only 60 s.

Figure 3 shows the hyper-Rayleigh and hyper-Raman of SrTiO_3 . The hyper-Raman peak is multiplied by a factor of 10 to be presented at the same plot as the hyper-Rayleigh. The hyper-Raman peak position compares well with the Vogt's and Inoue's results [25,26] and was acquired with only 60 s, a very short time compared to another systems [27–29]. The high peak intensity of the pulsed laser allows one to access the second order tensors and only femtosecond lasers can provide these short acquisition times. The high repetition rate of 80 MHz also helped. Typically, picosecond lasers with repetition rates as low as few kHz were used to perform hyper-Raman measurements, which leads to acquisition times of the order of a few hours. Inoue, for instance, spent almost 2 hours to measure a peak and Tezuka spent one day. These are the first studies of hyper Raman using femtosecond lasers.

Figure 4 shows the two-photon fluorescence emission in the blue region for the trapped polystyrene microspheres, curve 1 for a $2.5 \mu\text{m}$ microsphere and curve 2 for a $6 \mu\text{m}$ microsphere. The spectra were obtained with an integration time of 60 s. One can see peaks in the blue fluorescence spectra of the larger microsphere that are not present in the spectra of the smaller microsphere. These peaks are the MDR modes of a single trapped microsphere excited by two-photon absorption.

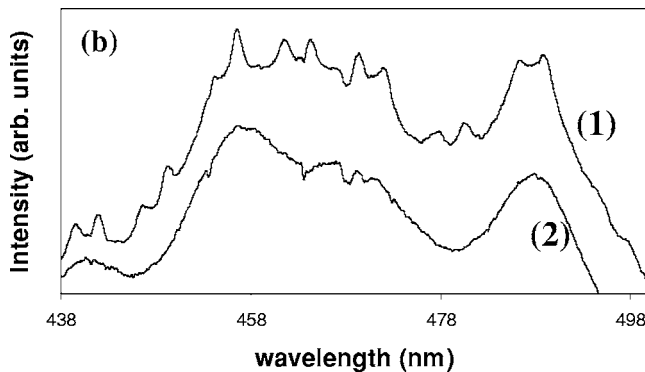

FIG. 4. Spectra of two-photon fluorescence for trapped polystyrene microspheres, curve (1) diameter of $6 \mu\text{m}$ and curve (2) diameter of $2.5 \mu\text{m}$. Curve (1) also shows the microsphere MDR modes.

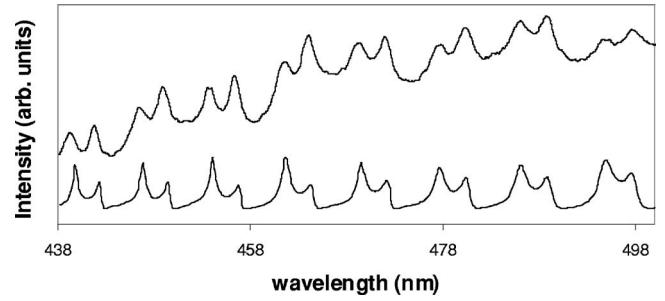

FIG. 5. Comparison between the theoretical and experimental MDR data.

In Fig. 5 we show the experimental results of the MDR modes compared with the theoretical calculation using the Mie theory [30,31]. The experimental MDR results were obtained by removing the background fluorescence, curves (2) of Fig. 4. The nominal diameter of the manufacturer is $(6 \pm 0.6) \mu\text{m}$.

We compared our experimental results with Mie theory using a similar method described by Chylek [32] comparing the shapes and locations of the peaks. The theoretical calculation was performed using the following dispersion relation $n_2 = 1.5683 + 10.087 \times 10^3 / \lambda^2$ for polystyrene and $n_1 = 1.324 + 3.046 \times 10^3 / \lambda^2$ for water, obtained from Ref. [33]. The best agreement was found for the microsphere diameter of $5.44 \mu\text{m}$, that is well within the nominal diameter range. The diameter adjustment was done by a code written in the Mathematica software. The peak maxima are obtained from the experimental curve and compared with the theoretical maxima values for a range of diameters. The theoretical peaks are calculated using the efficiency function Q for back-scattering light:

$$Q_b = \left| \sum_n (2n+1)(-1)^n (a_n - b_n) \right| / x^2,$$

with the size parameter $x = ka$, where a is the microsphere radius, and wave number $k = 2\pi n_1 / \lambda$, where λ is the wavelength and n_1 is the fluid refractive index. The a_n and b_n are the Mie coefficients for the transverse magnetic (TM) and transverse electric (TE) modes, respectively,

$$a_n = \frac{m^2 j_n(mx) [x j_n(x)]' - j_n(x) [m x j_n(mx)]'}{m^2 j_n(mx) [x h_n^1(x)]' - h_n^1(x) [m x j_n(mx)]'}$$

$$b_n = \frac{j_n(mx) [x j_n(x)]' - j_n(x) [m x j_n(mx)]'}{j_n(mx) [x h_n^1(x)]' - h_n^1(x) [m x j_n(mx)]'}$$

The TM and TE modes begin with a_{57} , b_{57} and finish with a_{50} , b_{50} . To find the correspondent modes we plot the coefficients a_n and b_n of the Mie theory and compare the values of wavelength for the experimental and coefficients peaks.

In conclusion, we have presented a setup of an optical tweezers combined with linear and nonlinear microspectroscopy capable to perform measurements of Raman, hyper-Raman, hyper-Rayleigh and two-photon luminescence. We observed Raman and two-photon luminescence for a single stained trapped microsphere of $6 \mu\text{m}$ diameter. The sensitiv-

ity of our system permitted the observation of the Mie resonances excited by two-photon absorption in the same trapped microsphere. We were also able to obtain a variety of Raman spectra and we observed hyper-Rayleigh and hyper-Raman peaks of SrTiO₃ in only 60 s. These spectroscopic techniques and the optical tweezers together in only one system

can provide a thorough analysis from visible to infrared regions of all kinds of living cells and other single trapped particles.

This work was supported by the Brazilian Agencies Capes, CNPq and FAPESP. This work is also part of the CEPOF (Optics and Photonics Research Center, FAPESP).

-
- [1] A. Ashkin and J. M. Dziedzic, *Science* **235**, 1517 (1987).
[2] K. Sakata-Sogawa *et al.*, *Eur. Biophys. J.* **27**, 55 (1998).
[3] K. König *et al.*, *Cell Mol. Biol. (Paris)* **42**, 501 (1996).
[4] V. Garcés-Chávez *et al.*, *Nature (London)* **419**, 145 (2004).
[5] G. J. Brouhar, H. T. Schek, and A. J. Hunt, *IEEE Trans. Biomed. Eng.* **50**, 121 (2003).
[6] H. Little *et al.*, *Opt. Express* **12**, 2560 (2004).
[7] D. G. Grier, *Nature (London)* **424**, 810 (2003).
[8] M. L. Barjas-Castro *et al.*, *Transfusion (Bethesda, Md.)* **42**, 1196 (2002).
[9] K. Ajito and K. Torimitsu, *Appl. Spectrosc.* **56**, 541 (2002).
[10] C. Xie, M. A. Dinno, and Y. Li, *Opt. Lett.* **27**, 249 (2002).
[11] B. R. Wood, B. Tait, and D. Macnaughton, *Biochim. Biophys. Acta* **1539**, 58 (2001).
[12] D. Morrish, X. Gan, and M. Gu, *Appl. Phys. Lett.* **81**, 5132 (2002).
[13] B. Agate *et al.*, *Opt. Express* **12**, 3011 (2004).
[14] K. König, *Histochem. Cell Biol.* **114**, 79 (2000).
[15] K. J. Vahala, *Nature (London)* **424**, 839 (2003).
[16] R. Symes, R. M. Sayer, and J. P. Reid, *Phys. Chem. Chem. Phys.* **6**, 474 (2004).
[17] X. Peng, *Appl. Phys. Lett.* **82**, 1497 (2003).
[18] S. Arnold *et al.*, *Opt. Lett.* **28**, 272 (2003).
[19] S. Arnold *et al.*, *Biophys. J.* **85**, 1974 (2003).
[20] R. D. B. Gatherer and J. P. Reid, *Chem. Phys. Lett.* **357**, 153 (2002).
[21] H. M. Nussenzveig, *Appl. Opt.* **42**, 1588 (2003).
[22] S. I. Shopova *et al.*, *Appl. Phys. Lett.* **85**, 6101 (2004).
[23] Y. Pan and R. K. Chang, *Appl. Phys. Lett.* **82**, 487 (2003).
[24] S. L. Zhang *et al.*, *Appl. Spectrosc.* **52**, 1264 (1998).
[25] H. Vogt, *Phys. Rev. B* **38**, 5699 (1988).
[26] K. Inoue and K. Watanabe, *Phys. Rev. B* **39**, R1977 (1989).
[27] K. Watanabe and K. Inoue, *J. Phys. Soc. Jpn.* **58**, 726 (1989).
[28] Y. Tezuka, S. Shin, and M. Ishigame, *Phys. Rev. B* **49**, 9312 (1994).
[29] K. Watanabe, K. Inoue, and F. Minami, *Phys. Rev. B* **46**, 2024 (1992).
[30] C. F. Bohren and D. R. Huffman, *Absorption and Scattering of Light by Small Particles* (John Wiley & Sons, New York, 1983).
[31] H. C. Van de Hulst, *Light Scattering by Small Particles* (Dover, New York, 1981).
[32] P. Chylek, V. Ramaswamy, A. Ashkin, and J. M. Dziedzic, *Appl. Opt.* **22**, 2302 (1983).
[33] J. B. Bateman, E. J. Weneck, and D. C. Eshler, *J. Colloid Sci.* **14**, 308 (1959).